

EZ Edge™ System



Armored Edge Joint Protection System for High-Traffic Areas

Guarantees a Perfect Joint

EZEdge™ joint assembly is a superior edge protection system for high-traffic areas, freezer buildings, and joint less floor designs, including:

- Shrinkage compensating concrete
- Post-tensioned
- Continuously reinforced
- Steel fiber reinforced

A fully fabricated unit, the EZEdge™ joint assembly incorporates the latest technology to ensure a smooth surface transition for forklift traffic and reduces long-term floor and fork truck maintenance costs.

Engineering Advantages

- Eliminates spalling for the life of the floor
- Provides superior edge protection
- Cold-rolled steel allows for installation to exacting tolerances
- EZEdge™ is shipped pre-mounted on the EZform™ board eliminating time consuming field “fit-ups”. The attached EZform™ board also comes standard with pre-cut dowel slots, which eliminate the need to nail dowel holders to traditional lumber
- Features a specially designed elastomer between the steel plates providing compressibility and elongation for concrete movement.
- EZEdge™ joint assembly performance is optimized with use of 90-degree angles, crosses and T's for precise tie-ins

Where significant slab movement is expected, steel plating of the joint edges is recommended; for strengthening the edges.

— ACI 302.1R-04

Cost Effective

- Eliminates onsite welding and grinding using skilled labor
- Comes pre-assembled and to desired slab depth

Easy to Use

- EZEdge™ is prefabricated, no jobsite assembly required
- EZEdge™ System is shipped in standard sizes, or to your specific height requirements creating an exact slab depth.
- The cold rolled steel has a unique proprietary bonding system, which eliminates removing nuts and bolts and cutting tack welds- meaning less chances of missing welds and potentially locking the slab.

Flooring contractors have stated that prefabricated armor joints save them more than 70% in time and labor costs.



Superior Products for the Concrete Flooring Industry

1-866-913-8363
www.McTechGroup.com

EZ Edge™ System



Material Specification and Product Information

EZedge™ SPECIFICATION

- All EZedge™ edge protection systems for high traffic areas, joint-less floor designs and freezer buildings will be supplied by McTech Group Inc. 1-866-913-8363.
- EZedge™ edge protection systems will be shear cut from cold-rolled steel per ASTM A36 to within 0.010" of specified size.
- Specially designed elastomer will be fitted between the steel plates to provide compressibility and elongation for concrete movement.
- EZedge™ edge protection system comes pre-mounted on the EZform™ form board for easier installation.
- EZedge™ comes in custom lengths up to 12 feet. A 4-inch offset is provided on the 12' lengths for assembly to adjacent forms.

EZdowel™ SPECIFICATION

- All EZform™ construction joint systems will be supplied by McTech Group Inc. 1-866-913- 8363.

EZdowel™

- EZdowel™ plate dowels will be shear cut from hot rolled plate per ASTM A36 to within 0.010" of specified size.
- Specially designed elastomer with compressible side material will be fitted to one side of the EZdowel™.
- EZdowel™ is available in 3/16, 5/16 and 3/8 inch thicknesses.

EZform™-board

- EZform™ boards will be manufactured engineered wood products developed for concrete forming using advanced resin technology.
- EZform™ boards will be overlaid with a resin impregnated Kraft paper in a primary process.
- Thickness of the form board is 1.125 inches with a tolerance of plus or minus .03125 inch
- Width of the EZform™ board is manufactured to specified depth of slab to a tolerance of plus or minus 0.010 inch.
- The slots that accept the EZdowel™ are spaced according to the structural design of the slab to a tolerance of plus or minus 0.010 inch.
- The slots that accept the EZdowel™ are centered in the form (unless specified otherwise) to a tolerance of 0.010 inch.
- EZform™ boards will be pre-chamfered at a 30° angle on the top of the form

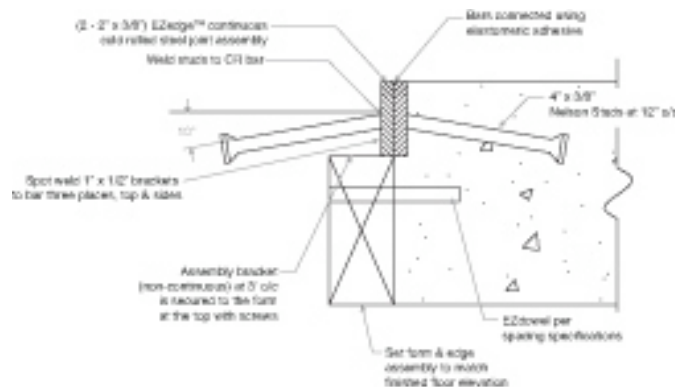

Superior Products for the Concrete Flooring Industry

1-866-913-8363
www.McTechGroup.com